

ISSN 1001-9006
CN 51-1333/TM

東方電氣評論

DONGFANG ELECTRIC REVIEW

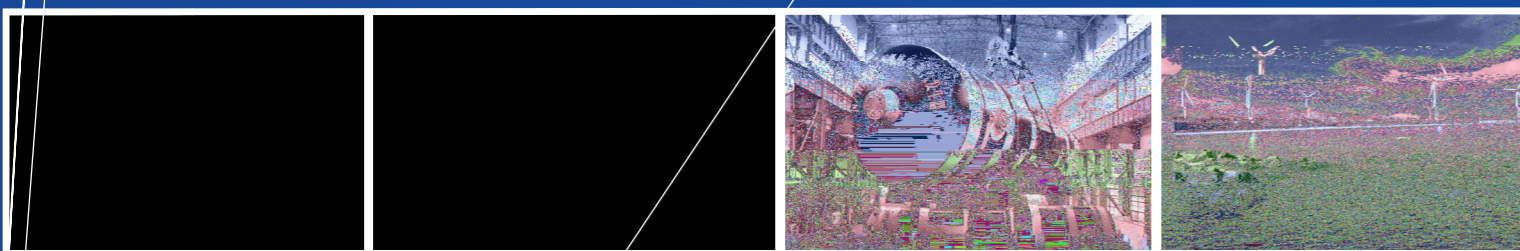

2
2026

第 40 卷第 2 期 总第 162 期
(双月刊, 1987 年创刊)

东方电气评论

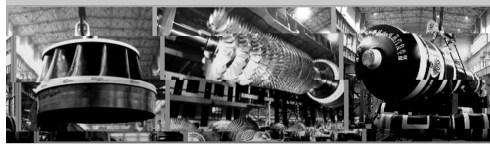

目次

编辑委员会

主任委员: 胡修奎

副主任委员: 董娜 唐健

委员: 王拯元 艾松 石清华 卢洪 令红兵
冯涛 刘泰生 刘德民 江国焱 孙奇
李维成 李婷 李曦滨 杨金炳 邹杰
宋聚众 陈文学 范小平 周杰 赵永智
钟连兵 莫尔兵 莫春鸿 铎林 梁权伟
舒华安 曾明富 谢光有 鄢治国 赖成毅
雷宇 潘绍成

秘书长: 唐健

主管: 中国东方电气集团有限公司

主办: 中国东方电气集团有限公司·四川省动力工程学会

主编: 胡修奎

副主编: 董娜 唐健

本期责任编辑: 李宏

英文编辑: 张媛

编辑出版: 《东方电气评论》编辑部

地址: 成都市高新西区西芯大道 18 号

邮编: 611731

电话: 028-87898263

电子信箱: dfdqpl@dongfang.com

投稿网址: <http://dfdqpl.xml-journal.net/>

(<https://www.manuscripts.com.cn/dfdqpl>)

印刷单位: 成都市新都华兴印务有限公司

国内发行: 四川省报刊发行局

国外发行: 中国出版对外贸易总公司北京 782 信箱

基础研究

- 一种大功率氢燃料电池保供车辆电源系统的集成设计 李宁 练勇 李洋等(1)
- 三步酸洗法提纯镓及其过程回收的工艺设计优化研究 吴移 戴明强 叶金文等(6)
- 电网不对称下交流励磁直流母线电压谐波抑制方法 吉磊 刘基涛(16)
- 变循环发动机模式转换中的流量再分配对风扇响应的影响 张智伟 余心远 张沛(21)

数字制造

- 基于人工势场函数的轮式移动机器人轨迹跟踪与避碰控制 汪浩 张伟 张宇等(26)

火力发电

- 基于在线更新的 LSSVR 与 PatchTSMixer 模型的燃煤机组脱硝入口 NO_x 浓度预测研究 赵雨秋 李平 金逸龙(35)
- 城市生活垃圾焚烧发电性能指标解析 江瑞宝 刘伟(41)
- 煤炭掺氨燃烧技术的研究进展及应用 张全军 郭焱桃 焦洋等(48)

水力发电

- 西藏 DG 高海拔水轮发电机设计概述 施明星 张景林 郑棣(56)

核能发电

- 核能发电机氢气密封用橡胶材料的寿命评估研究 刘从辉 王建立 王勇(60)

风力发电

- 覆冰条件下风电场发电机组叶片表面防除冰技术研究 夏新龙(66)
- 基于改进滑模观测器的永磁同步发电机无速度传感器控制 胡俊 单小衍 吴小田等(72)

工程技术

- 中小汽轮发电机转子装配一体式工位研制 徐正乾 付显栋 郎建强(76)
- 锂电池储能液冷热管理技术开发研究 常博 朱睿 王晶等(81)

[期刊基本参数]CN51-1333/TM*1987*B*A4*88*zh*p*¥8.00*750*14*2026-02

DONGFANG ELECTRIC REVIEW

2

2026

2026-03-25 Vol. 40 No.2
(Bimonthly, since 1987)

CONTENTS



BASIC RESEARCH

An Integrated Design of High-power Hydrogen Fuel Cell Power System for Vehicle LI Ning, LIAN Yong, LI Yang, et al(1)

Study on Process Design and Optimization for Gallium Purification by Three-step Acid Washing and Its Recovery

..... WU Yi, DAI Mingqiang, YIN En, et al(6)

A Harmonic Suppression Method for AC Excitation DC Bus Voltage under Unbalanced Power Grid I Lei, LIU itao(16)

Effect of Flow Redistribution on Fan Response during Mode Transition in Variable Cycle Engine LIN Fei, YU in an, LIN Fei(21)

DIGITAL MANUFACTURING

Trajectory Tracking Control without Collisions for the Wheel Mobile Robot Base on Artificial Potential Function

..... WANG Tao, LIU Wei, LIU Yi, et al(26)

THERMAL POWER

Research on Predicting NO_x Concentration at the SCR Inlet of A Coal-fired Unit Using Online-updated LSSVR and PatchTSMixer Models

..... LIU Yiqi, LIU Jing, LIU Yilong(35)

Analysis of Performance Indicators for Municipal Solid Waste-to-energy Incineration LI Ning, LIU Tao, LIU Wei(41)

Research Progress and Application of Coal Ammonia-doped Combustion Technology LIU Nan, U Yantao, LI Yang, et al(48)

HYDRAULIC POWER

Overview of High Altitude Hydro-generator Design for Xizang DG Power Station LI Mingxing, LIAN Jinglin, LIU Di(56)

NUCLEAR POWER

Life Prediction of Rubber Used in Hydrogen Sealing System of Nuclear Power Turbine Generators LIU Yong, WAN Jianli, WAN Yong(60)

WIND POWER

Research on Anti-icing and De-icing Technologies for Wind Turbine Blade Surfaces under Icing Conditions LI Anlong(66)

Speed Sensorless Control of PMSG Based on Improved Sliding Mode Observer LIU Jun, DAN Jiaohan, WU Jiaotian, et al(72)

ENGINEERING

Development of an Integrated Workstation for Rotor Assembly of Medium and Small Steam Turbine Generators

..... LIU Mengqian, LIU Jiantong, LIAN Jianqiang(76)

Research and Development of Liquid Cooling Thermal Management Technology for Lithium Battery Energy Storage

..... LIAN Jiao, LIU Jia, WAN Jing, et al(81)

EDITORIAL BOARD

Chairman: HU Xiukui

Vice-Chairman: DONG Na, TANG Jian

Editorial Board: WANG Zhengyuan, AI Song, SHI Qinghua, LU Hong, LING Hongbing, FENG Tao, LIU Taisheng, LIU Demin, JIANG Guoyan, SUN Qi, LI Weicheng, LI Ting, LI Xibin, YANG Jinbing, ZOU Jie, SONG Juzhong, CHEN Wenxue, FAN Xiaoping, ZHOU Jie, ZHAO Yongzhi, ZHONG Lianbing, MO Erbing, MO Chunhong, DUO Lin, LIANG Quanwei, SHU Huaan, ZENG Mingfu, XIE Guangyou, YAN Zhiguo, LAI Chengyi, LEI Yu, PAN Shaocheng

Chief Editor: TANG Jian

Editorial Department: Dongfang Electric Corporation

Chief Editor: HU Xiukui

Vice-Chief Editor: DONG Na, TANG Jian

Editor: LI Hong

Editorial Board: ZHANG Yuan

Editorial Board: LI Hong

Editorial Department of Dongfang Electric Review
No. 18 Xi Xin Avenue, Gao Xin Xi District, Chengdu,
Sichuan, P. R. China

Phone: 611731

Tel: 028-87898263

Email: dfdqpl@dongfang.com

Submission Website: <http://dfdqpl.xml-journal.net/>
(<https://www.manuscripts.com.cn/dfdqpl>)

Organized by:

China National Publishing Industry Trading Corporation
(P. O. Box 782, Beijing, P. R. C.)

[Redacted]					
1 2	1 2	1 2	1 2	1 2	1 2
1.				611731	

1

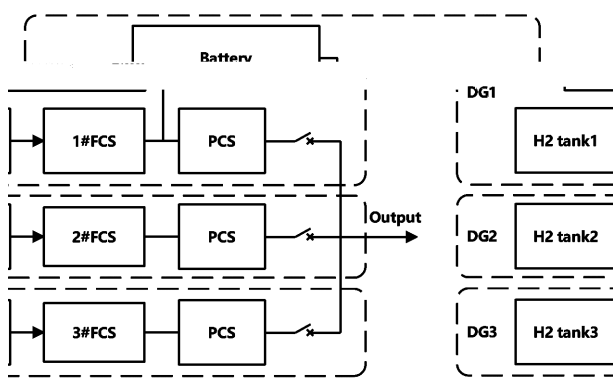

2

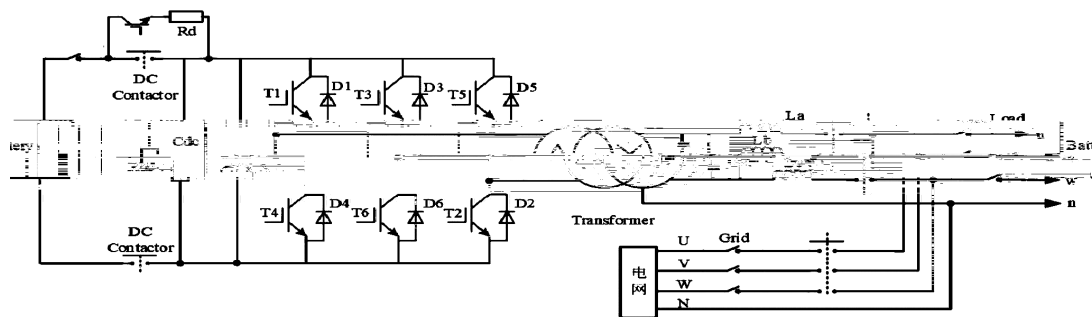
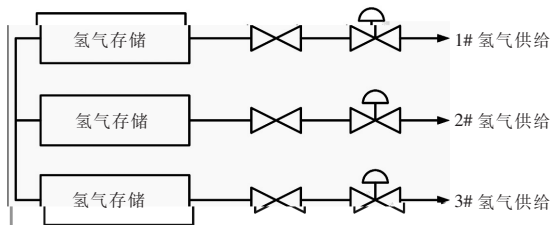
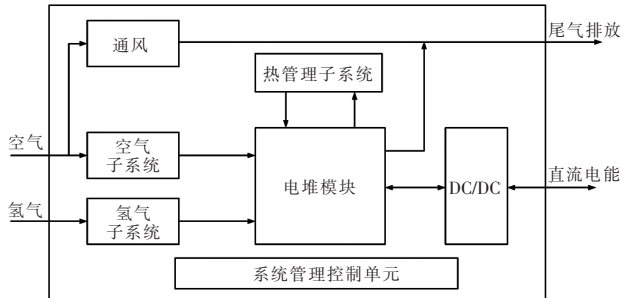

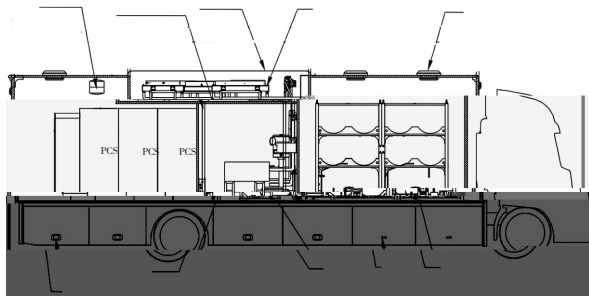
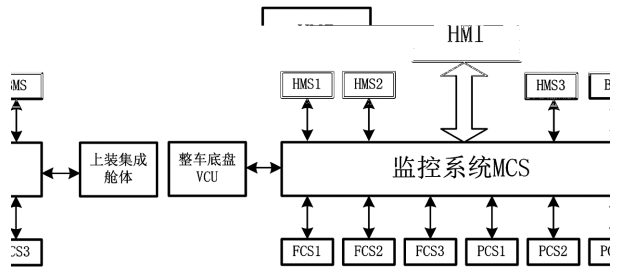
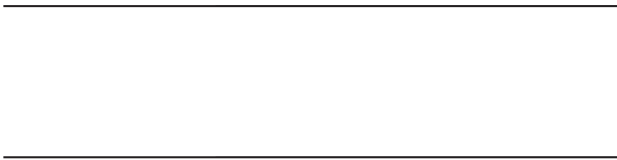

3

[Redacted]					
1 2	1 2	1	2	2	
1.	610065	2.			6

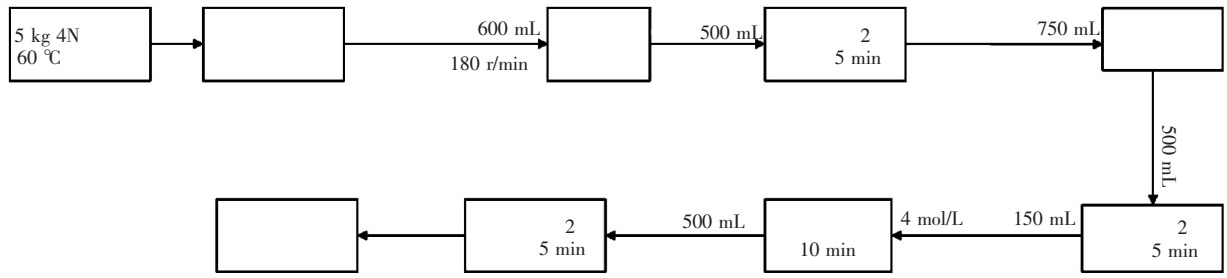

2

R T K

n E R k
T

G RT K
r k Hⁿ Ea/RT

G G

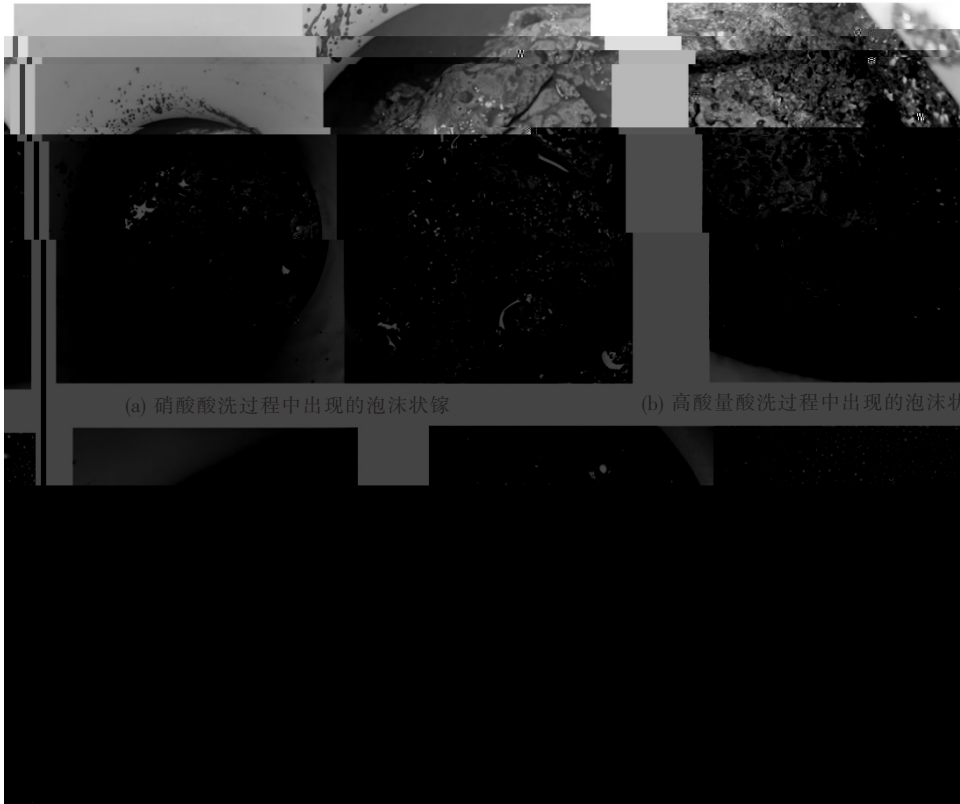

P /R R

:

3



1 PWM

a b c
 I
 I
 V
 L R
 E z
 V



$$\begin{bmatrix} E \\ E \\ E \end{bmatrix} \begin{bmatrix} V \\ V \\ V \end{bmatrix} L \frac{1}{t} \begin{bmatrix} i \\ i \\ i \end{bmatrix} R \begin{bmatrix} i \\ i \\ i \end{bmatrix}$$

E
 V
 E
 i
 E
 i E

R dq

$$\begin{bmatrix} E \\ E \end{bmatrix} \begin{bmatrix} V \\ V \end{bmatrix} j L$$

$$\begin{bmatrix} P \\ Q \\ P \\ P \end{bmatrix} \begin{bmatrix} E^p & E^p & E^n & E^n \\ E^p & E^p & E^n & E^n \\ E^n & E^n & E^p & E^p \\ E^n & E^n & E^p & E^p \end{bmatrix} \begin{bmatrix} I^p \\ I^p \\ I^n \\ I^n \end{bmatrix}$$

P P

Q

P

$$\begin{bmatrix} P \\ Q \end{bmatrix} \begin{bmatrix} E & E \\ E & E \end{bmatrix} \begin{bmatrix} I \\ I \end{bmatrix} \begin{bmatrix} E & E \\ E & E \end{bmatrix}$$

$$\begin{bmatrix} E & E \\ E & E \end{bmatrix} \begin{bmatrix} E & E \\ E & E \end{bmatrix} \begin{bmatrix} I \\ I \end{bmatrix}$$

$$\begin{bmatrix} I^p \\ I^p \\ I^n \\ I^n \end{bmatrix} \frac{P}{D} \begin{bmatrix} E^p \\ E^p \\ E^n \\ E^n \end{bmatrix} \frac{Q}{D} \begin{bmatrix} E^p \\ E^p \\ E^n \\ E^n \end{bmatrix}$$

D

Q

$$\begin{bmatrix} P \\ Q \end{bmatrix} \begin{bmatrix} E & E \\ E & E \end{bmatrix} \begin{bmatrix} I \\ I \end{bmatrix} \begin{bmatrix} E & E \\ E & E \end{bmatrix} \begin{bmatrix} I \\ I \end{bmatrix}$$

$$\begin{bmatrix} \\ \end{bmatrix} \begin{bmatrix} E & E \\ E & E \end{bmatrix} \begin{bmatrix} I \\ I \end{bmatrix} \begin{bmatrix} E & E \\ E & E \end{bmatrix} \begin{bmatrix} I \\ I \end{bmatrix}$$

$$\begin{bmatrix} E & E \\ E & E \end{bmatrix} \begin{bmatrix} E & E \\ E & E \end{bmatrix}$$

$$\begin{bmatrix} \\ \end{bmatrix} \begin{bmatrix} E & E \\ E & E \end{bmatrix} \begin{bmatrix} E & E \\ E & E \end{bmatrix}$$

$$\begin{bmatrix} E & E \\ E & E \end{bmatrix} \begin{bmatrix} I \\ I \end{bmatrix} \begin{bmatrix} E & E \\ E & E \end{bmatrix} \begin{bmatrix} I \\ I \end{bmatrix}$$

L

$$\begin{bmatrix} & t & \\ & t & \\ | & | & | & | & T \end{bmatrix}$$

$$\begin{bmatrix} | \\ | \end{bmatrix} | \begin{bmatrix} & t & \\ & t & \end{bmatrix} |$$

$$\begin{bmatrix} & t & \\ & t & \end{bmatrix} \begin{bmatrix} | \\ | \end{bmatrix}$$

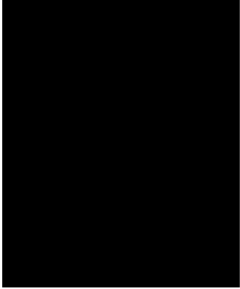

m

m

t

t

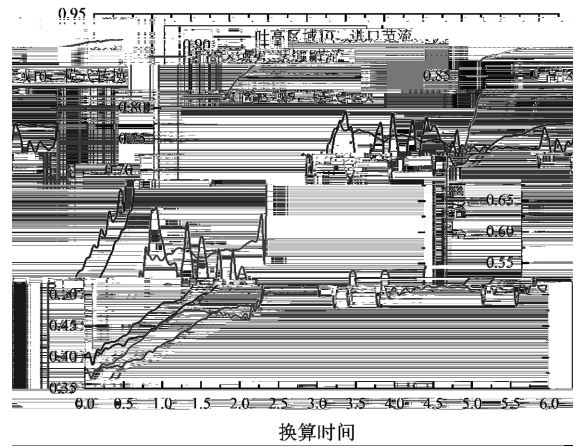
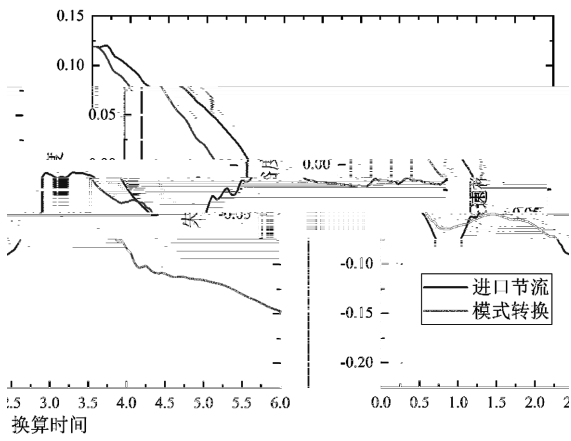

$$D \frac{W}{W} \frac{W}{W} \frac{W}{W} \frac{W}{W}$$

$$D \quad W$$

$$W \quad W$$

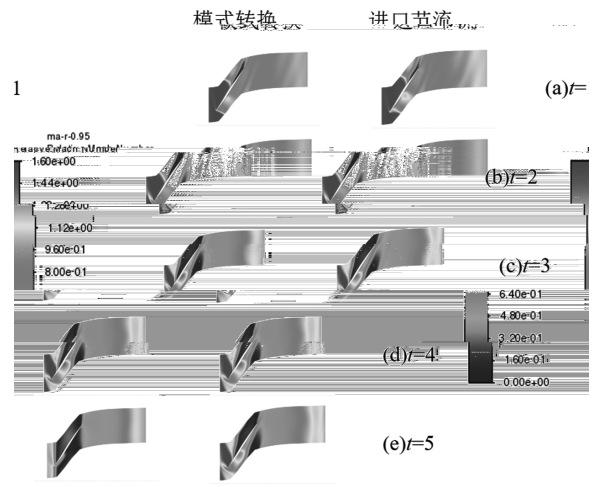



618000

： ， （ ） ，
“ ” ， （ ） 。 ，
、 ，
： ； ； ；
：

：
：

1 WMR

O

G

O G XOY d

XOY

XOY

XOY p t x t y t t

\mathbb{R} x t y t

XOY t

XOY

A t p t

$$A \begin{matrix} t & t & t & d \end{matrix} \mathbb{R} \quad \begin{matrix} p^r t & p t \\ , \end{matrix}$$

$$p t \begin{bmatrix} t & d & t \\ t & & \\ & d & t \\ t & t & \end{bmatrix} \begin{bmatrix} t \\ t \end{bmatrix}$$

$$\begin{bmatrix} x^r t & y^r t & r^r t \end{bmatrix} \mathbb{R} \quad \begin{matrix} p^r t \\ e t \end{matrix}$$

$$\begin{bmatrix} e t & e t & e t \end{bmatrix} \mathbb{R}$$

XOY

$$e t \quad p^r t \quad p t \quad \begin{bmatrix} x^r t & x t \\ y^r t & y t \\ r^r t & t \end{bmatrix}$$

XOY

e

t

$$e t \quad T \quad t e t$$

$$e t \quad [e t \quad e t \quad e t] \quad \mathbb{R}$$

T t

\mathbb{R}

$$T_e t \quad \begin{bmatrix} t & t \\ t & t \end{bmatrix}$$

t

$$e t \quad \begin{bmatrix} r^r t & e t & t & t e t \\ & r^r t & e t & t e t \\ & & r^r t & t \\ r^r t & r^r t & & \end{bmatrix}$$

t e t

$$\sqrt{\begin{matrix} x & t & x & t \\ y & t & y & t \end{matrix}}$$

$$U \ t \ \left\{ \begin{array}{l} - \left(\frac{d \ t \ R}{d \ t \ R} \right) \\ d \ t \ R \quad t \\ - \left(\frac{d \ t \ R}{d \ t \ R} \right) \\ (\ t \ t) \\ d \ t \ R \quad t \\ (\ t \ t) \\ R \ d \ t \ R \quad t \\ R \ d \ t \end{array} \right.$$

$$j \quad d \ t \quad U \ t$$

$$x \ y$$

XOY

U t

$$F \ t \ \left\{ \begin{array}{l} j \\ d \ t \\ \frac{U \ t}{x \ t} x \ \frac{U \ t}{y \ t} y \\ d \ t \ R \quad t \\ \frac{U \ t}{x \ t} x \ \frac{U \ t}{y \ t} y \\ \frac{U \ t}{t} \quad \frac{U \ t}{t} \\ d \ t \ R \quad t \\ \frac{U \ t}{t} \quad \frac{U \ t}{t} \\ R \ d \ t \ R \quad t \\ R \ d \ t \end{array} \right.$$

$$F \ t$$

d t

$$\frac{U \ t}{x \ t} \frac{d \ t \ R}{d \ t \ R} \left(\frac{d \ t \ R}{d \ t \ R} \right) x \ t \ x \ t$$

$$\frac{U \ t}{y \ t} \frac{d \ t \ R}{d \ t \ R} \left(\frac{d \ t \ R}{d \ t \ R} \right) y \ t \ y \ t$$

$$\frac{U \ t}{t} \quad (\ t \ t) \quad t \quad t$$

$$\frac{U \ t}{t} \quad t \quad t \quad t \quad t$$

e t e t

!

$$\frac{U_t}{e^t} = \frac{U_t}{e^t} + F_t$$

$$x \quad y \quad T_t \quad \mathbb{R}$$

$$T_t \begin{bmatrix} t & t \\ t & t \end{bmatrix}$$

t

$$r_t = \frac{1}{d} (F_t + k E_t) d$$

$$r_t = \frac{1}{d} (F_t + k E_t)$$

$$t \quad F_t \quad k E_t$$

$$t \quad \frac{1}{d} (F_t + k E_t)$$

k μ

$$V_t = \left(e^{-rt} + \frac{dk}{k} e^{-rt} \right)_j^M U_t$$

V

t t

$$V_t = kE_t + kE_t + \frac{k}{k} e^{-rt}$$

$$(E_t e^{-rt} + E_t e^{-rt}) t$$

$$t t t \frac{d}{d}$$

$$(kE_t + ke_t) t V_t$$

V

μ k $\left\{ \begin{array}{l} - \\ \end{array} \right\}$ k μ
 V t

3

k k k
 R

R

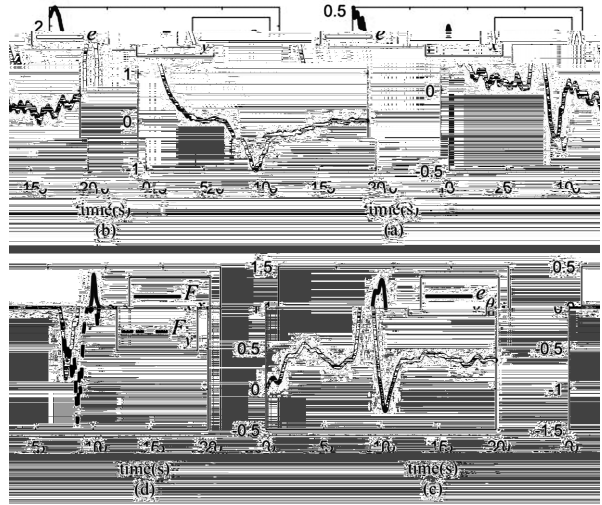

k k k
 R

R

t

t

t

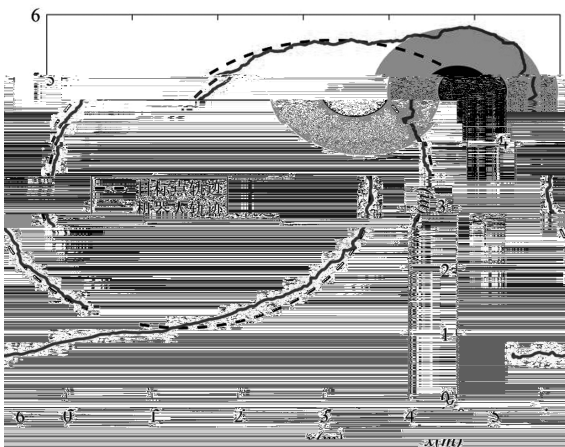

x y

t

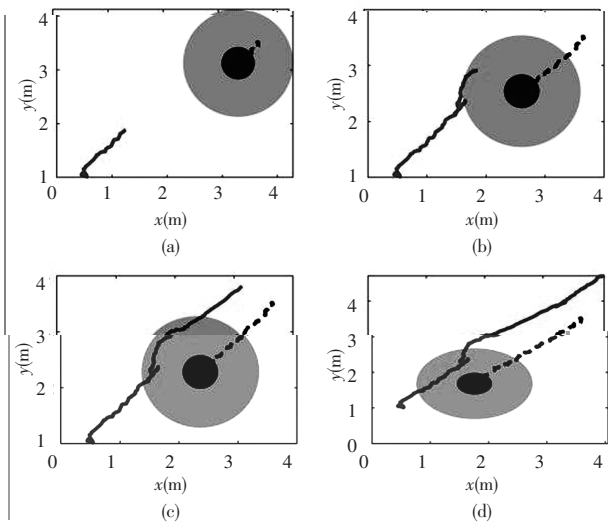

:

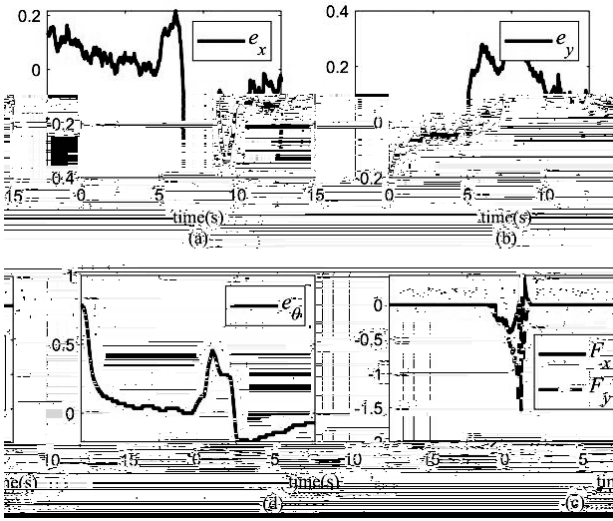

x y

t

LSSVR PatchTSMixer NOx

611731

摘要：基于某电厂某炉内历史运行数据，研究开发了SCR入口NOx浓度预测模型。模型采用Python实现，以炉内负荷、煤质、氧量、燃烧器挡板开度等运行参数为输入特征。对比研究了在线更新的LSSVR和PatchTSMixer两种模型。结果表明，LSSVR模型在RMSE、MAE和R²等评价指标上均优于PatchTSMixer模型。此外，LSSVR模型还具有训练速度快、泛化能力强、非线性拟合性能好的特点。

关键词：NOx浓度预测；在线更新的LSSVR；PatchTSMixer；建模；模型对比分析

Research on Predicting NOx Concentration at the SCR Inlet of A Coal-fired Unit Using Online-updated LSSVR and PatchTSMixer Models

ZHAO Yuqiu LI Ping JIN Yilong

Abstract: Based on historical operational data from a MW coal-fired unit at a power plant, this study developed a predictive model for NOx concentration at the inlet of the denitrification (SCR) system. Implemented using Python, the model takes key operating parameters such as unit load, coal feed rate, flue gas oxygen content, and burnout damper opening as input features. Two algorithms online-updated Least Squares Support Vector Regression (LSSVR) and the Patch-based Time Series Mixer (PatchTSMixer) were employed for model construction and performance comparison. The results show that, in terms of evaluation metrics including RMSE, MAE, and the coefficient of determination (R²), the LSSVR model outperforms the PatchTSMixer model in prediction accuracy. Additionally, the LSSVR model demonstrates faster training speed, better generalization capability, and stronger nonlinear fitting performance.

Key words: NOx concentration prediction; online-updated LSSVR; PatchTSMixer; modeling; model comparative analysis

!

:
:

1

$$K x x \quad x x$$

C

$$y^i \quad N \quad D \quad x^i \quad f$$

$$x y$$

$$d \quad x x^i$$

mini d

N

$$D D \quad x y$$

f

$$e \quad y f \quad x \quad e$$

x^i

$$i \quad \text{argmin}_i \quad x x^i$$

$$D \quad D \quad x^i \quad y^i \quad x y \quad f$$

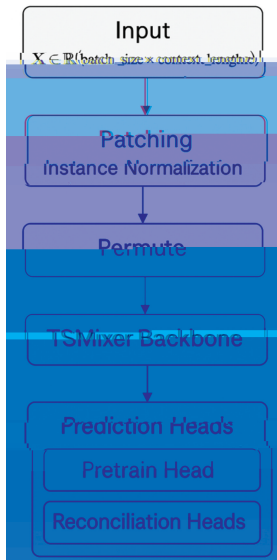

n

!

$$R = \frac{\sum_{i=1}^n \frac{y_i - \bar{y}}{n} \frac{y_i - \bar{y}}{n}}{\sqrt{\sum_{i=1}^n \left(\frac{y_i - \bar{y}}{n}\right)^2 \sum_{i=1}^n \left(\frac{y_i - \bar{y}}{n}\right)^2}}$$

2

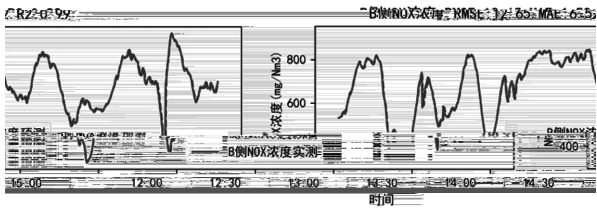
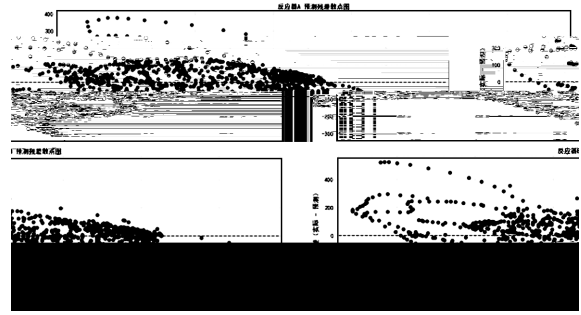
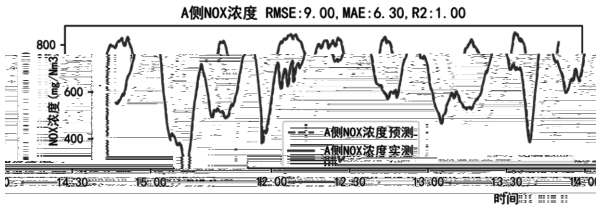
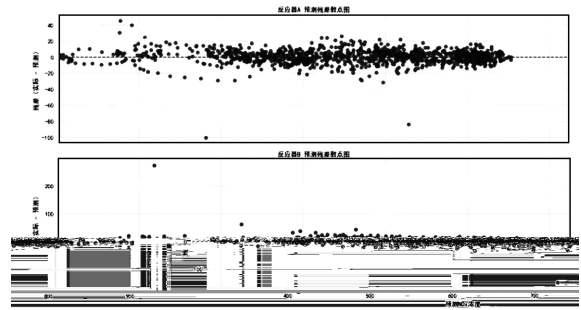
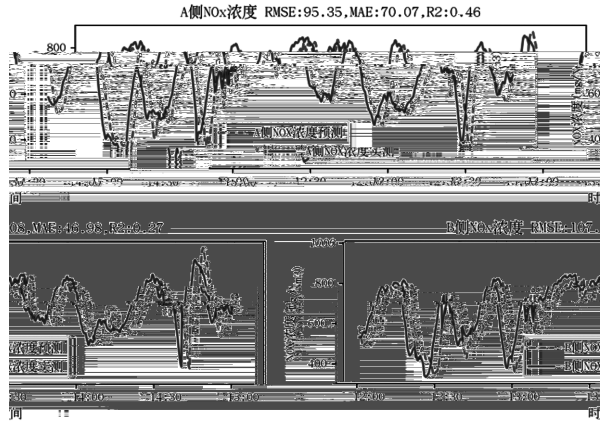

! ! !

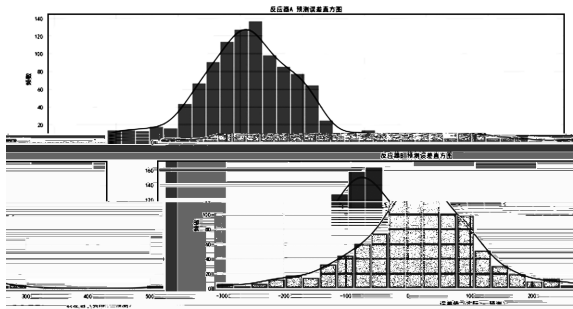
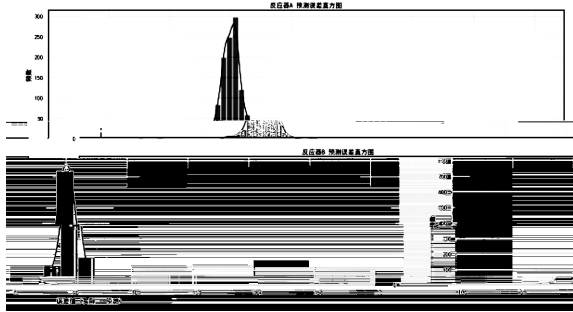

3

:



611731

：
○，
○
：；；；
：；：：（）

Analysis of Performance Indicators for Municipal Solid Waste-to-energy Incineration

JIANG Ruibao LIU Wei

Abstract: This paper focuses on the performance indicators of municipal solid waste-to-energy, extracts and analyzes relevant provisions from national and industry standards associated with waste-to-energy incineration projects. It provides an in-depth interpretation of the underlying policy orientations and technical principles governing these regulations. Drawing upon extensive practical experience in bidding processes and project implementation cases, the study refines, categorizes, and summarizes critical performance indicators, offering valuable decision-making support and reference benchmarks for industry professionals.

Key words: waste-to-energy; performance indicators; indicator analysis; environmental compliance metrics

1

：

：



q q q

5

:

market demands. Through systematic analysis and synthesis of the technology s principles, current research status, application cases, existing issues, and development prospects, this paper provides a reference framework for further advancing the development and application of coal-ammonia co-combustion technology.

Key words: coal ammonia-doped combustion; low carbon combustion technology; combustion characteristics; NO_x control; thermal power carbon reduction

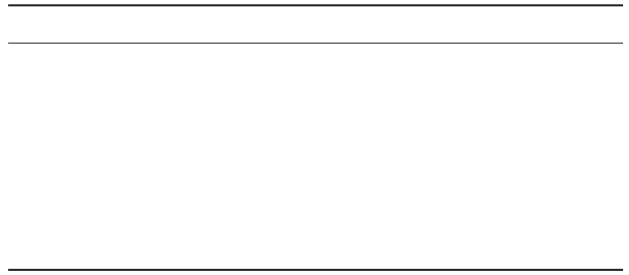

1

DG

618000

: , \ ,
, \ ,
: ; ; ; ; ; ; ;
: : ()

Overview of High Altitude Hydro-generator Design for Xizang DG Power Station

SHI Mingxing ZHANG Jinglin ZHEN Di

Abstract: Based on the condition of high altitude hydropower station, this paper mainly introduced the electromagnetic design, insulation and anti-corona technology optimization and ventilation system structure optimized design of high altitude hydro-generator, which solved the problem such as corona, discharge and heat dissipation difficulties.

Key words: high altitude; hydro-generator; electromagnetic design; insulation; anti-corona; heat dissipation; ventilation system

1

2

:
:

3

Q



618000

: () , — ,
、 、 , ,
: ; ; ; : ()
:

Life Prediction of Rubber Used in Hydrogen Sealing System of Nuclear Power Turbine Generators

LIU Conghui WANG Jianli WANG Yong

Abstract: For Nuclear Power Turbine Generators(generator parts), hydrogen sealing is one of the most important seals, and the research about the aging life of their rubber sealing materials is an important part of improving the reliability of nuclear power units. In this paper, two rubber materials, fluororubber and EPDM, are selected for using in nuclear power hydrogen seals, and their compressive stress relaxation, Shore A hardness, leakage rate and other properties are investigated respectively, and the service life of these two materials is estimated by using the Arrhenius equation, and the service life of these two materials on the unit is derived in theory, which provides a theoretical basis and reference for the replacement cycle of hydrogen seals in nuclear power units.

Key words: nuclear power; hydrogen sealing; fluoroelastomer; EPDM; life pre

:
:

2

3

4

1

()

5

()

$\frac{F}{F}$

F
 F

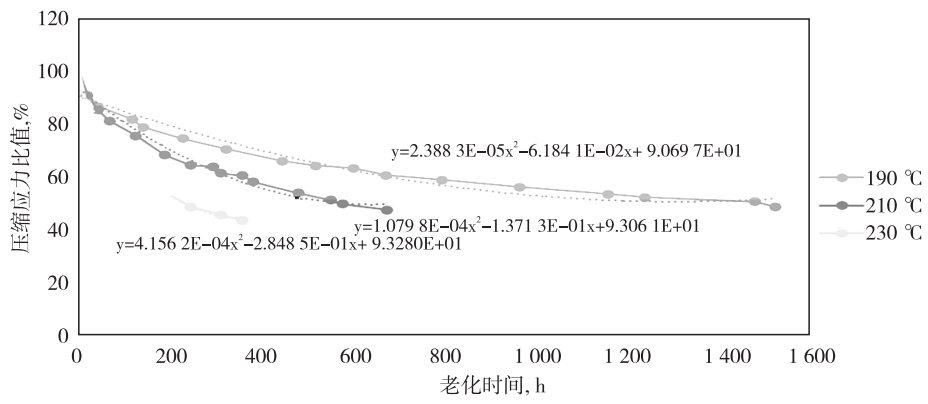

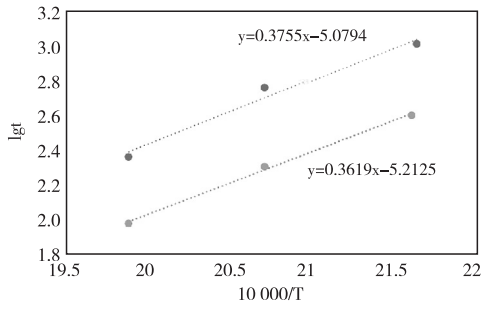

● 压缩应力
比值达到
70%

● 压缩应力
比值达到
50%

()



() , 610000

: , , , ,
, ,

:
:

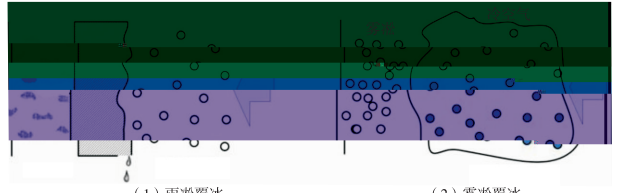

(1) 雨淋覆冰

(2) 雾淋覆冰

$$\begin{cases} \frac{1}{w} \times u + u - \\ + t \times q \quad q w \\ w \quad u \end{cases}$$

$$L = E \frac{D}{q} u + u -$$

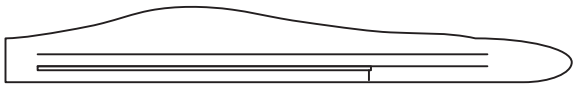

$$E = \omega - q \quad q \times Y$$

$$D \frac{1}{t} \quad E$$

$$E \quad o$$

$$D$$

$$N \quad q \quad -L$$

$$N$$

$$T \frac{1}{C} N$$

$$T \quad C$$

2

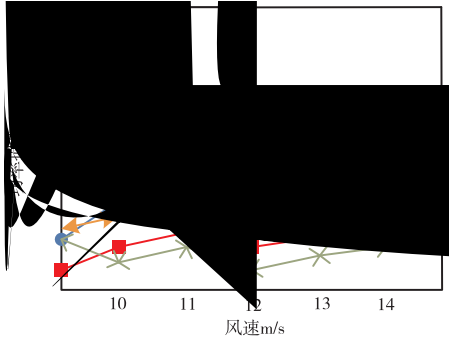

:



610000

: , .
.
:
: ; ; ; : ()

Speed Sensorless Control of PMSG Based on Improved Sliding Mode Observer

HU Jun DAN Xiaoyan WU Xiaotian LI Xiyan

Abstract: To address the problem of insufficient estimation accuracy caused by the discontinuous switching control characteristic of traditional sliding mode observers, this paper proposes an improved sliding mode observer design method. By introducing a new type of continuous switching function to replace the traditional sign function and designing an adaptive sliding mode gain, the high-frequency chattering phenomenon of the sliding mode observer is suppressed, and the estimation accuracy of speed and position is improved. To verify the effectiveness of the proposed method, a simulation model of a . MW permanent magnet wind power generation system is built in the MATLAB/Simulink environment. Simulation results show that compared with the traditional sign function method and the boundary layer method, the proposed method exhibits superior performance in both speed estimation and electrical angle estimation.

Key words: PMSG; speed sensorless; sliding mode observer; switching function

:
:

$$\begin{matrix} \overline{t} \begin{bmatrix} i \\ i \end{bmatrix} \\ \overline{L} \begin{bmatrix} u \\ u \end{bmatrix} \end{matrix} \begin{bmatrix} \frac{R}{L} & \frac{L \ L}{L} \\ \frac{L \ L}{L} & \frac{R}{L} \end{bmatrix} \begin{matrix} \begin{bmatrix} i \\ i \end{bmatrix} \\ \overline{L} \begin{bmatrix} E \\ E \end{bmatrix} \end{matrix}$$

$$\begin{matrix} \overline{t} \begin{bmatrix} \hat{i} \\ \hat{i} \end{bmatrix} \\ \hat{L} \begin{bmatrix} u \\ u \end{bmatrix} \end{matrix} \begin{bmatrix} \frac{R}{L} & \frac{L \ L}{L} \\ \frac{L \ L}{L} & \frac{R}{L} \end{bmatrix} \begin{matrix} \begin{bmatrix} \hat{i} \\ \hat{i} \end{bmatrix} \\ \hat{L} \begin{bmatrix} v \\ v \end{bmatrix} \end{matrix}$$

$$\begin{matrix} \overline{t} \begin{bmatrix} i \\ i \end{bmatrix} \\ \overline{L} \begin{bmatrix} E \ v \\ E \ v \end{bmatrix} \end{matrix} \begin{bmatrix} \frac{R}{L} & \frac{L \ L}{L} \\ \frac{L \ L}{L} & \frac{R}{L} \end{bmatrix} \begin{matrix} \begin{bmatrix} i \\ i \end{bmatrix} \\ \overline{L} \begin{bmatrix} E \ v \\ E \ v \end{bmatrix} \end{matrix}$$

1

$$\begin{matrix} \begin{bmatrix} u \\ u \end{bmatrix} \\ \begin{matrix} R \\ u \end{matrix} \begin{bmatrix} i \\ i \end{bmatrix} \\ \begin{matrix} L \\ u \end{matrix} \begin{bmatrix} L \\ L \end{bmatrix} \end{matrix} \begin{bmatrix} L \ L \\ L \end{bmatrix} \begin{matrix} \begin{bmatrix} i \\ i \end{bmatrix} \\ \overline{t} \begin{bmatrix} i \\ i \end{bmatrix} \\ \begin{bmatrix} E \\ E \end{bmatrix} \end{matrix}$$

$$\begin{bmatrix} v \\ v \end{bmatrix} h \begin{bmatrix} i \\ i \end{bmatrix} h \begin{bmatrix} \hat{i} \\ \hat{i} \end{bmatrix}$$

dq

$$\begin{bmatrix} E \\ E \end{bmatrix} \begin{bmatrix} L \ L \\ \left(i \ \overline{t} i \right) \end{bmatrix} \begin{bmatrix} \end{bmatrix}$$

$$f \ x \ \frac{\quad}{e^{ax}} \quad a \quad f \ x \quad a$$

a

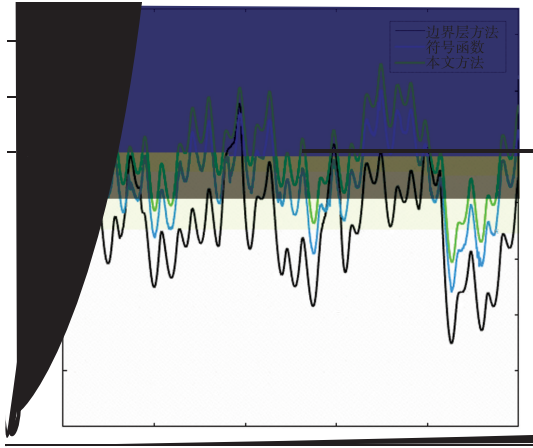

3

1

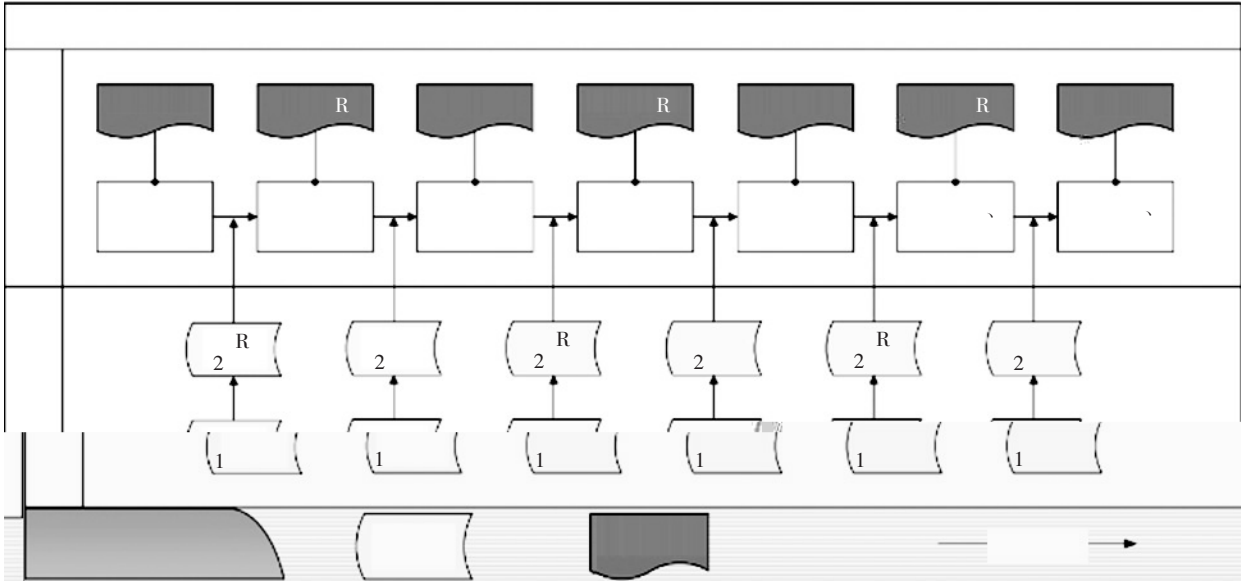

2

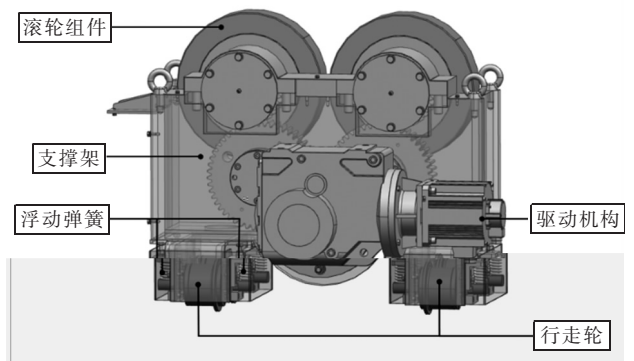
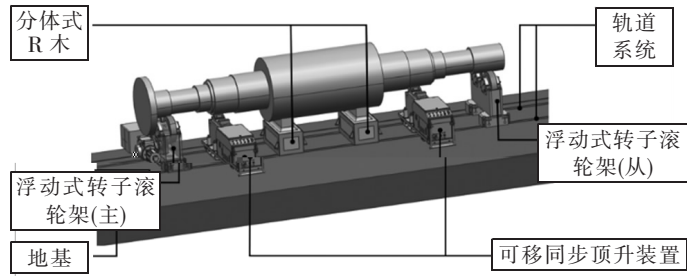

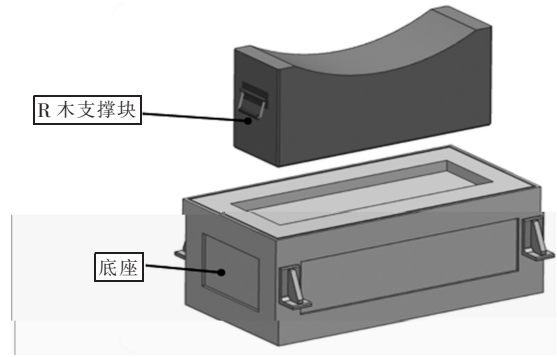
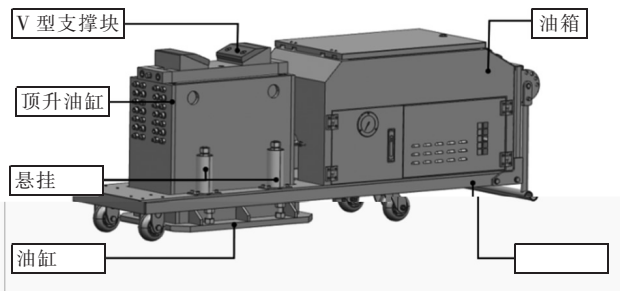

3

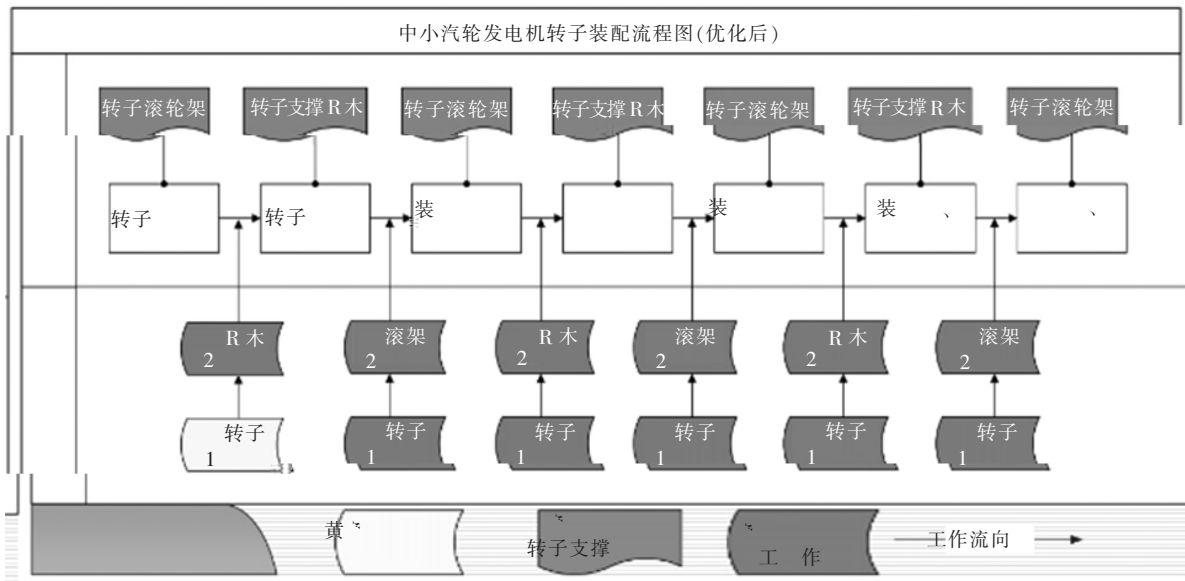

5

4

:

1

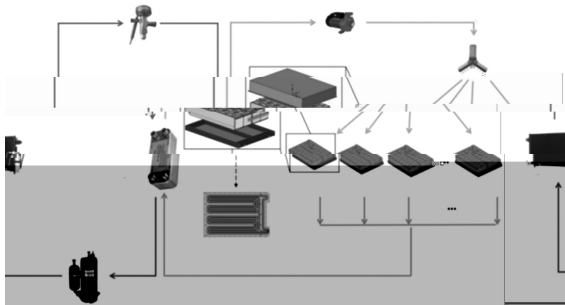

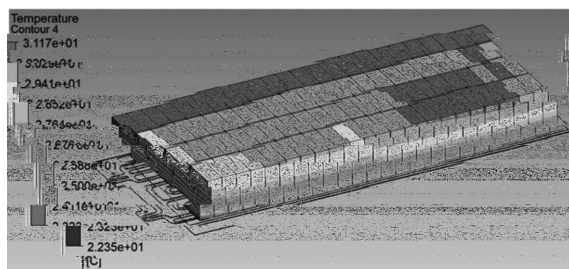
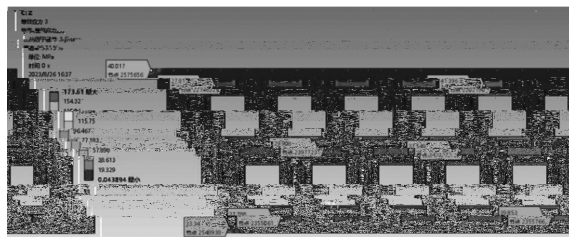
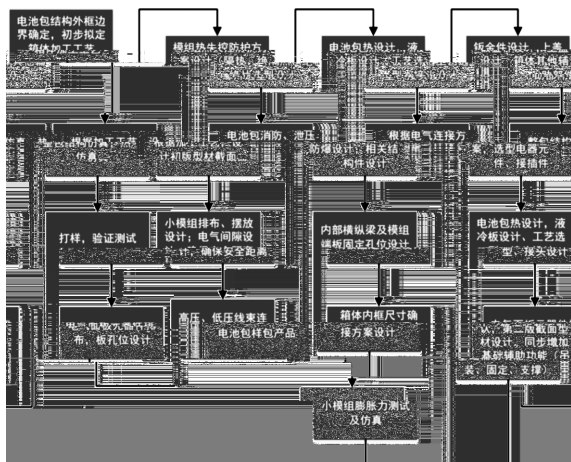

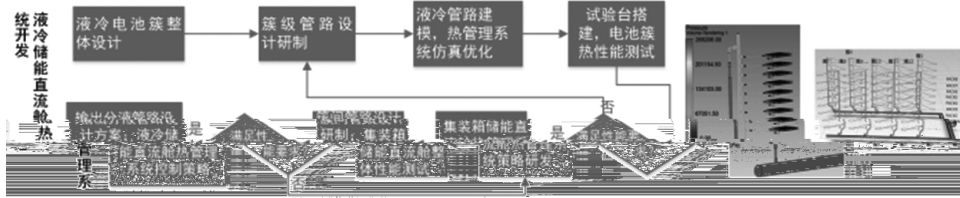

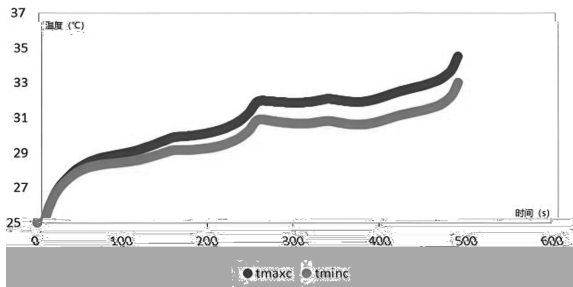
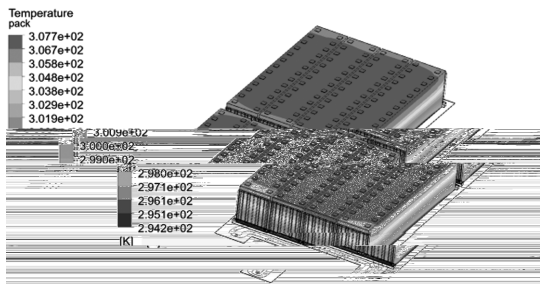

3

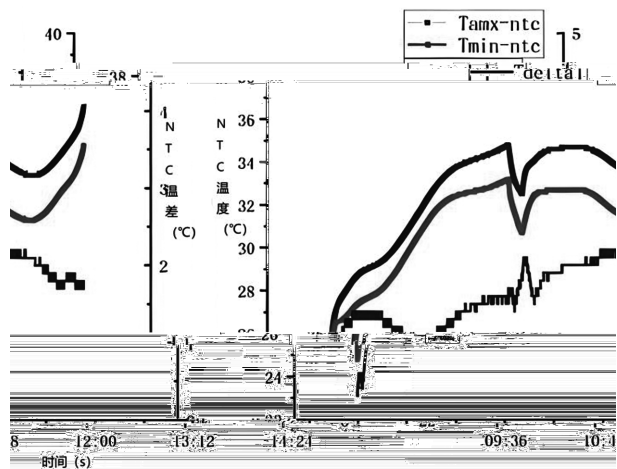

()

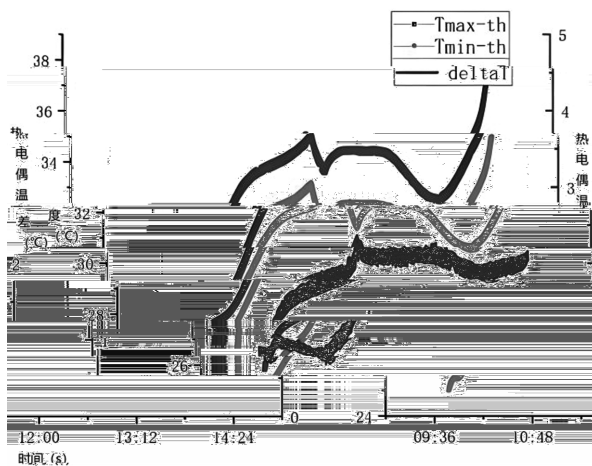

()

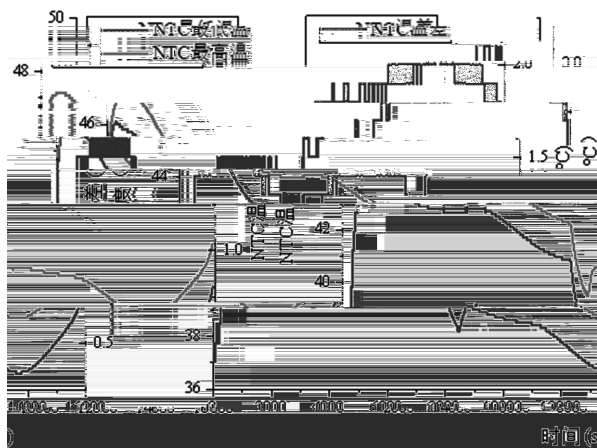

()

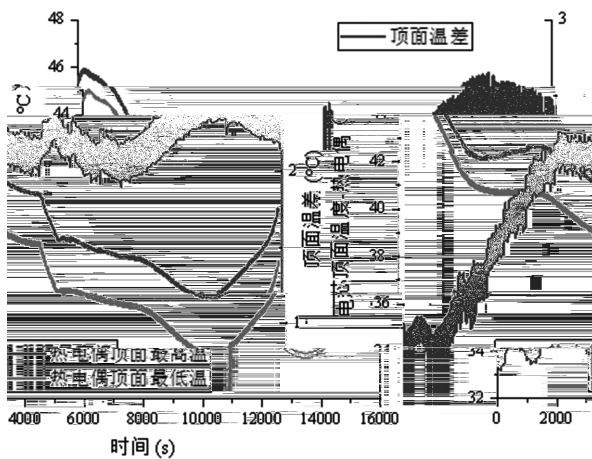

()

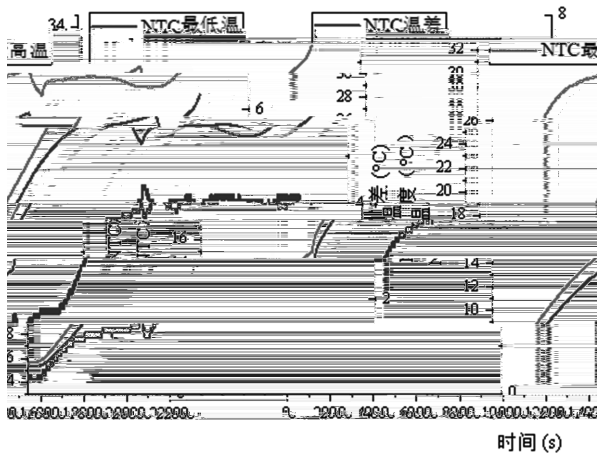

()



()

: